

Proportional Directional Valves with Feedback

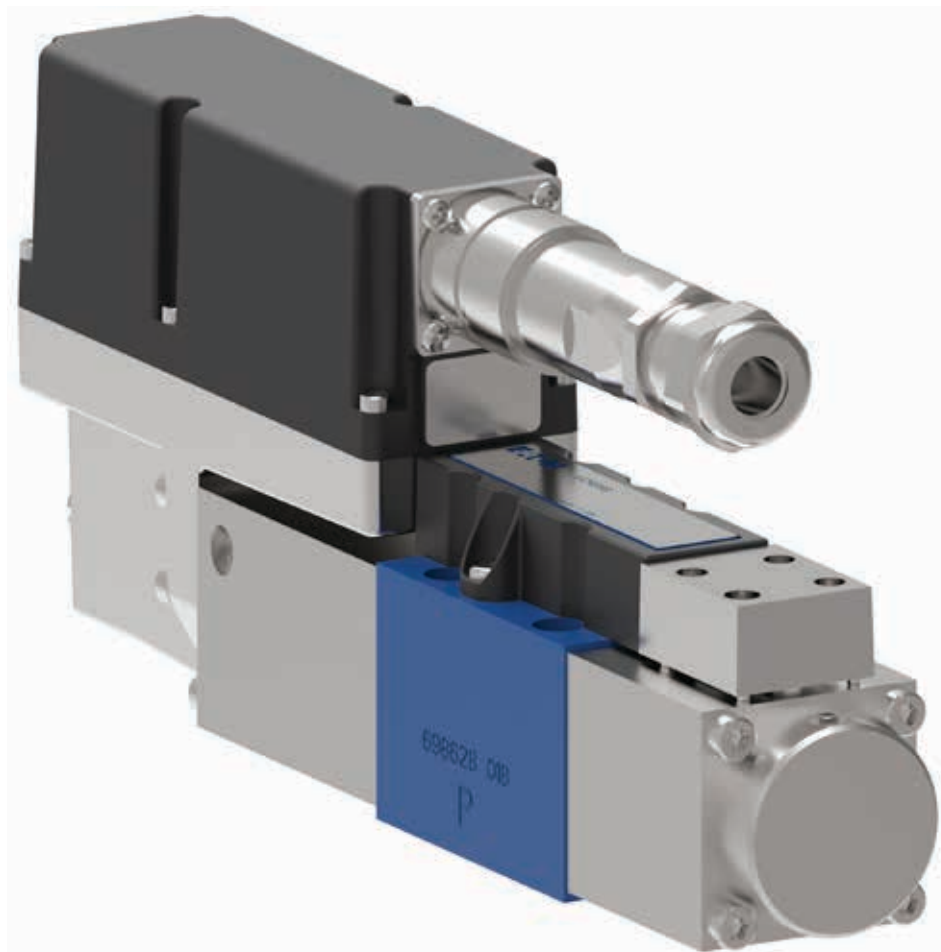

Content

INTRODUCTION

Typical section view	03
Model code	04
Spool data	05
Functional symbols	05

OPERATING DATA

Valves with amplifier, KBFD/TG4V-3	06
Valves without amplifier, KFD/TG4V-3	07
KBFD/TG4V-3 & KFD/TG4V-3	07
Pressure and flow rates	07

PERFORMANCE CURVES

Power capacity envelopes, single solenoid models	08
Power capacity envelopes, double solenoid models	08
Flow gain curves	09
Frequency response	09

INSTALLATION DIMENSIONS

KFDG4V-3	10
KFTG4V-3	10
KBFDG4V-3	11
KBFTG4V-3	11

SUBPLATES AND MOUNTING SURFACES

Mounting surface interface to ISO 4401 (size 03)	12
--	----

ELECTRICAL INFORMATION

Block diagram voltage input (M1)	13
Block diagram current input (M2)	14
Wiring connection voltage input (M1)	15
Wiring connections current input (M2)	16

APPLICATION DATA



This product has been designed and tested to meet specific standards outlined in the European Electromagnetic Compatibility Directive (EMC) 2014/30/EU which repealed Directive 89/336/EEC, amended by Directives 91/263/EEC, 92/31/EEC, 93/68/EEC and 93/97/EEC. For instructions on installation requirements to achieve effective protection levels, see the leaflet and Installation Wiring Practices for Eaton's Electronic Products leaflet 2468. Wiring practices relevant to this Directive are indicated by Δ Electromagnetic Compatibility (EMC).

Eaton® K(B)FD/ TG4V proportional valves are designed to provide a controlled oil flow in direct proportion to a command signal. They are available in two types; a double solenoid version that will provide reversible flow to an actuator and a single solenoid throttle version that provides a single direction of flow. Hydrostats are available for load compensation and parallel flow path modules are available that will boost the flow capacity of single solenoid throttle versions to nearly twice that of the standard valve. Additionally, both of these valve types can be supplied with or without an integral amplifier built directly onto the valve.

KFD/TG4V-3

This version is supplied without the integral amplifier.

Features and benefits

- Wide range of spool and flow rate options
- Electronic feedback LVDT ensures accurate spool position control
- Vibration and shock tested
- Supported by a broad range of amplifiers and auxiliary function modules Full CE electromagnetic compatibility

KBFD/TG4V-3 A

Range of proportional directional and throttle valves with integral control electronics. Factory-set adjustments of gain, spool deadband compensation and offset ensure consistent repeatability valve-to-valve.

The only electrical inputs required are power supply (24V) and a voltage command signal of $\pm 10V$ or 4-20 mA. The amplifier is housed in a robust metal enclosure, sealed against ingress of water and other fluids. Electrical connections are via a standard 7-pin plug.

A spool position monitor pin allows the function of the valve to be electrically monitored. Ramp functions, if required, can be generated externally.

Features and benefits

- Factory-sealed adjustments ensure valve to valve reproducibility
- Installation wiring reduced and simplified
- Standard 7-pin connector
- Standard 24V DC supply with wide tolerance band
- Optional $\pm 10V$ DC or 4-20 mA command signals
- Valve with integrated amplifier selected, ordered, delivered and installed as one performance- tested package
- Spool position monitor pin to help with troubleshooting
- Simple valve removal and replacement for service (plug and play)
- Vibration and shock tested
- Auxiliary DIN rail mounted electronic function modules available
- Full CE electromagnetic compatibility.- 2014/30/EU
- IP65 and IP67 valve environmental protection rating
- Optional valve enable function

Typical section view

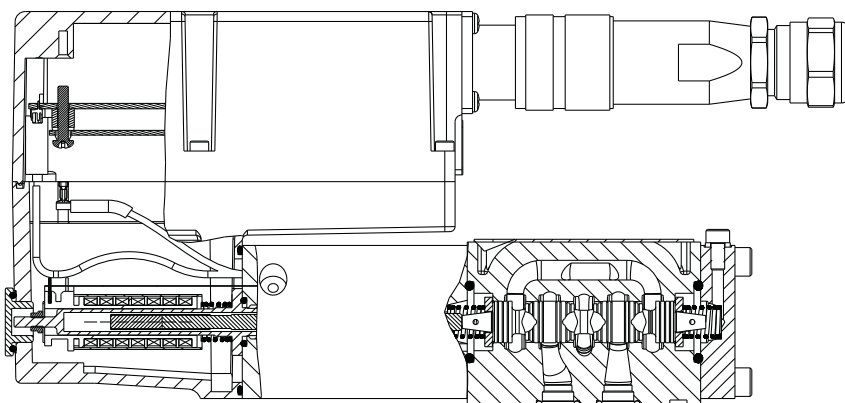

KBFD/TG4V-3-*PE7, 1* Design

Model codes

K	(B)	F	*	G	4	V	-3-	**	*	**	*	**	-Z-	(V)-	(M)-	-(U1)	-(***)	-H-	*-	12	EN***
1	2	3	4	5	6	7	8	9	10	11	12	13	14	15	16	17	18	19	20	21	22

1	Valve type	K	Proportional valve
2	Integral amplifier	B	Integral amplifier "B" series. Omit for models without integral amplifier
3	Feedback arrangement	F	Spool position
4	Control type	D	Directional valve
		T	Throttle valve
5	Mounting	G	Subplate mounted
6	Operation	4	Solenoid operation
7	Pressure rating	V	350 bar (5000 psi) on ports P, A & B
8	Interface	3	
9 10	2C - All ports closed at center, KBD		
11 12	2C03F		3 L/min symmetric, fine meter in/fine meter out
	2C07N		7 L/min symmetric, meter in/ meter out
	2C13N		13 L/min symmetric, meter in/ meter out
	2C20N		20 L/min symmetric, meter in/ meter out
	2C20N10		20 L/min /10 L/min , meter in/ meter out
	2C28S		28 L/min symmetric, meter out only
	2C30N		30 L/min symmetric, meter in/ meter out
	33C – P closed at center, A,B,T connected, KBD		
	33C03F		3 L/min symmetric, fine meter in/fine meter out
	33C07N		7 L/min symmetric, meter in/ meter out
	33C08N04		9 L/min /4 L/min , meter in/ meter out
	33C13N		13 L/min symmetric, meter in/ meter out
	33C20N		20 L/min symmetric, meter in/ meter out
	33C20N10		20 L/min /10 L/min , meter in/ meter out
	33C27N		27 L/min symmetric, meter in/ meter out
	5C – zero lap		
	5C20N		20 L/min symmetric, meter in/ meter out
	5C30N		30 L/min symmetric, meter in/ meter out
	31C – A and P closed at center, B connected to T, KBD		
	31C13N		13 L/min symmetric, meter in/ meter out
	31C20N		20 L/min symmetric, meter in/ meter out
	2B single solenoid throttle valves, KBT		
	2B03F		3 L/min symmetric, fine meter in/fine meter out
	2B07N		7 L/min symmetric, meter in/ meter out
	2B13N		13 L/min symmetric, meter in/ meter out
	2B20N		20 L/min symmetric, meter in/ meter out
	2B27N		27 L/min symmetric, meter in/ meter out
	2B30N		30 L/min symmetric, meter in/ meter out

13 14 Flow rating ("B" port flow for asymmetric spools) K(B)FDG valves only

10 L/min (2.64 USgpm) (20N10 only)
Omit for symmetrical spools

Manual overrides

Z No manual overrides

15 Solenoids energization identity

(Non-integral amplifier types KF only, omit for valves with integral amplifier)

V Solenoid "A" is at port "A" end and Solenoid "B" is at port "B" end independent of spool type

Blank US ANSI B93.9 standard (energize solenoid "A", flow symbol is (P>A))

16 Command input

M Electrical feature flag (KF only)

M1 +/-10V command and +/-10V feedback

M2 4-20mA command and +/-10V feedback

M3 +/-10V command and 4-20mA feedback

M4 4-20mA command and 4-20mA feedback

17 Solenoid connector

Omit for valves with integral amplifier KBF

U1 ISO 4400/DIN 43650, non-integral amplifier type KF only (mating plug supplied)

18 Electrical connection (KBF valves only)

PE7 7-pin electrical plug with mating half

PH7 As PE7 but with pin "C" used for enable signal

19 Coil rating

H 24 VDC amplifier supply

20 Port T pressure limit code

6 For 2C**S spools

7 For all other spools

21 Design number 1* & 2* series

Subject to change

22 EN090 Resin filled,20G

EN119 Polyurethane interface seals

Note: Additional configurations available upon request. Please contact your customer sales representative for details.

All dimensions are in inches.

WARNING

Valves with integral amplifier are supplied with or without the metal 7-pin plug. The Eaton plug, part no. 934939, must be correctly fitted to ensure that the EMC rating and IP67 rating are achieved. The plug retaining nut must be tightened with a torque of 2-2.5 Nm (1.5-2.0 lbf ft) to effect a proper a proper seal)

Spool symbols

Available spools for K(B)FDG4V-3

Spool type 2C**N, meter-in/meter-out

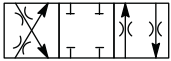

Spool type 5C**N, meter-in/meter-out (zero lap)



Spool type 2C28S, meter-out only

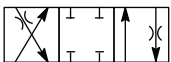

Spool type 33C**N, meter-in/ meter-out

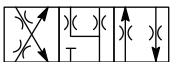

Spool type 31C**N, meter-in / meter out

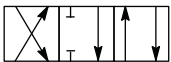

Asymmetric spools

Figure preceding metering type designator, "N" (e.g. 2C**N) is flow rating P-A, or A-T ("A" port flow); figure after "N" (N**) is flow rating P-B, or B-T ("B" port flow).

Available spools for K(B)FTG4V-3

Spool type 2B**N, meter-in/meter-out

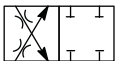

Functional symbols

Model types KBFDG4V-3

Proportional directional valve (with integrated electronics)

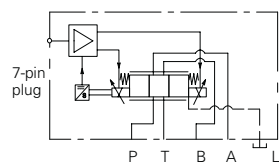

Model types KBFTG4V-3

Proportional throttle valve (with integrated electronics)

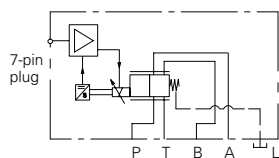

Spool type and flow rating

Symmetric spools

Base line starting at $\Delta p = 5$ bar (75 psi) per metering flow pat, e.g. B to T. For actual maximum flow refer to power capacity envelope curves.

For K(B)FDG4V-3 valves

Spool code	Spool symbol	Flow rating
2C03F	2C	3 L/min (0.79 USgpm)
2C07N	2C	7 L/min (1.85 USgpm)
2C13N	2C	13 L/min (3.43 USgpm)
2C20N	2C	20 L/min (5.28 USgpm)
2C30N	2C	30 L/min (7.92 USgpm)
2C28S	2C	28 L/min (7.40 USgpm)
33C03F	33C	3 L/min (0.79 USgpm)
33C07N	33C	7 L/min (1.85 USgpm)
33C13N	33C	13 L/min (3.43 USgpm)
33C20N	33C	20 L/min (5.28 USgpm)
33C27N	33C	27 L/min (7.13 USgpm)
5C20N	5C	20 L/min (5.28 USgpm)
5C30N	5C	30 L/min (7.92 USgpm)

For K(B)FTG4V-3 valves

Spool code	Spool symbol	Flow rating
2B03F	2B	03 L/min (0.79 USgpm)
2B07N	2B	07 L/min (1.85 USgpm)
2B13N	2B	13 L/min (3.43 USgpm)
2B20N	2B	20 L/min (5.28 USgpm)
2B27N	2B	27 L/min (7.13 USgpm)
2B30N	2B	30 L/min (7.92 USgpm)

For K(B)FDG4V-3 valves

Spool code	Spool symbol	Flow rating
2C20N10	2C	20 L/min (5.28 USgpm), "A" port flow 10 L/min (2.64 USgpm), "B" port flow
33C20N10	33C	20 L/min (5.28 USgpm), "A" port flow 10 L/min (2.64 USgpm), "B" port flow
33C08N04	33C	08 L/min (2.11 USgpm), "A" port flow 04 L/min (1.06 USgpm), "B" port flow

Model types KFDG4V-3

Proportional directional valve (requires amplifier card)

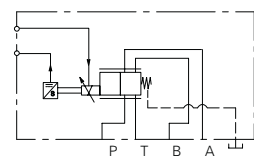

Model types KFTG4V-3

Proportional throttle valve (requires amplifier card)

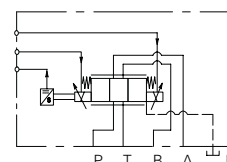

Operating data

K(B)FD/TG4V-3 valves with amplifier

KBFD/TG4V-3 valves with Integral amplifier

Data is typical with fluid at 36 cSt (168 SUS) and 50° C (122° F).

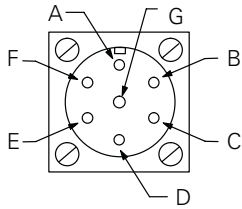
Power supply	24V DC (18 V to 36V including 10% peak-to-peak max. ripple) max current 3A
Command signal	
Voltage mode M1	0 to +10V DC, or 0 to -10V DC, or -10V to +10V DC
• Input impedance	47K Ohm
• Common mode voltage to pin B	18V (max)
Current mode M2	4-20 mA
• Input impedance	100 Ω
• Max differential voltage to pin E to pin D	10V
Valve enable signal for model codes PH7	
Enable	>8.5V (36V max)
Disable	<6.5 V
Input impedance	10K Ohm
7-pin plug connector	Pin Description
View of pins of fixed half	A Power supply positive (+)
	B Power Supply 0V
	C Not connected (PE7)
	C Valve enable (PH7)
	D Command signal (+V or current IN)
	E Command signal (-V or current GND)
	F Output monitor
	G Protective ground

Electromagnetic compatibility (EMC)

Conducted Emissions CISPR11 -2015-06 Ed 6.0/EN55011 - Class A, 150kHz to 30MHz
Radiated Emissions CISPR11 -2015-06 Ed 6.0/EN55011 - Class A, 30MHz – 1GHz
RF Continuous Conducted disturbances IEC 61000-4-6, Class A 150 KHz to 80 MHz
• DC Power Port : 10Vrms
• Signal/Control Port : 10Vrms
RF Electromagnetic Field, 80 MHz to 2700 MHz, 10V/m, Meets Criterion A
Surge: IEC 61000-4-5
• DC Power Port : ±1kV
• Signal/Control Port : ±1kV
Electrical Fast Transients IEC 61000-4-4, Class B
• DC Power Port : ±2kV
• Signal/Control Port : ±1kV
Electrostatic discharges (ESD) IEC 61000-4-2, Class B
• Air ±8kV,
• Contact ±4kV

Threshold command voltage (minimum voltage for minimum flow)	0.25V
--	-------

Monitor signal (pin F)

KBFD valves	± 10V DC for full spool stroke
KBFT valves	0 to -10 V DC for full spool stroke
Voltage mode	+/- 10V DC for full stroke
Output impedance	10KOhm
Current mode	4mA to 20mA
Output impedance	Upto 200 Ohm
Power stage PWM frequency	10 kHz nominal

Electronic amplifier is compliant to 2011/65/EU ROHS2

Step input response with flow through P-A-B-T Δ p=5 bar (75 psi) per metering path, e.g. P-A

Required flow step:	Time to reach 90% of required step:
0 – 100%	17 ms
100% – 0	16 ms
+90 – -90% (KBFDG4V-3 only)	25 ms
Reproducibility, valve-to-valve (at factory settings):	
Flow at 100% command signal	≤ 5%

Protection	
Electrical	Reverse polarity protected
Environmental	IEC 60529, Class IP65 and IP67
ROHS compliance	
Electronic amplifier is compliant to 2011/65/EU ROHS2	
Ambient air temperature range for full performance	-40°C to +85°C (-40°F to 185°F)
Oil temperature range for full performance	0° C to 70° C (32° F to 158° F)
Minimum temperature at which valves will work at reduced performance	-40°C (-40°F)
Storage temperature range	-40°C to +85°C (-40°F to 185°F)
Supporting products auxiliary electronic modules (DIN -rail mounting):	
EHD-DSG-201-A-1* command signal generator	See catalog GB 2470
EHA-RMP-201-A-2* Ramp generator	See catalog GB 2410A
EHA-PID-201-A-2* PID controller	See catalog GB 2427
EHA-PSU-201-A-10 Power supply	See catalog GB 2410A

KFD/TG4V-3 valves without amplifier

KFD/TG4V-3 Valves without Integral amplifier (requires a Eurocard Amplifier, refer to supporting products)

Data is typical with fluid at 36 cSt (168 SUS) and 50° C (122° F).

Max current, at 50° C (122° F)	2.7 A
Coil resistance, at 20° C (68° F)	1.87 Ω
Step response	
Step size (% of max spool stroke)	Time to reach 90% of required step:
0 – 100%	18 ms
100% – 0	19 ms
+90 – -90% (KBFDG4V3-3 only)	30 ms
Type of protection, with electrical plugs fitted correctly	IEC60529, Class IP65
Electromagnetic compatibility (EMC)	
Emmission (10V/m)	EN 50081-2
Immunity (10V/m)	EN 50082-2
Maximum allowable ambient air temperature	60° C (140° F)
Maximum allowable oil temperature	60° C (140° F)
Supporting products:	
Eurocard amplifiers - EEA PAM 533 A/B/C/D/E/F	See catalog GB-2464

KFD/TG4V-3 and KBFD/4V-3 valves (all valves)

Relative duty factor	Continuous rating (ED = 100%)
Hysteresis with flow through P–A–B–T	<1% of max stroke (center-to-offset)
Mass:	
KFDG4V-3	2.7 kg (5.9 lb) approx.
KBFDG4V-3	3.1 kg (6.8 lb) approx.
KFTG4V-3	2.1 kg (4.6 lb) approx.
KBFTG4V-3	2.5 kg (5.5 lb) approx.

Pressure and flow rates

Maximum pressures, bar (psi)

Model	Port L condition	Ports P, A, B	T	L
All models for normal usage (L port not connected) 105 (1500)	Normally blocked by mounting surface	315 (4500)	160 (2300) 350 (5000)	160 (2300) 105 (1500)
For K(B)FDG4V-3**C**N/F-Z models only a higher "T" port pressure is allowed if the "L" port is connected directly to tank.	Drained directly to tank	350 (5000)	210 (3000)	10 (150)

Performance curves

Power capacity envelopes

Single solenoid models:

K(B)FTG4V-3

Spool types as noted

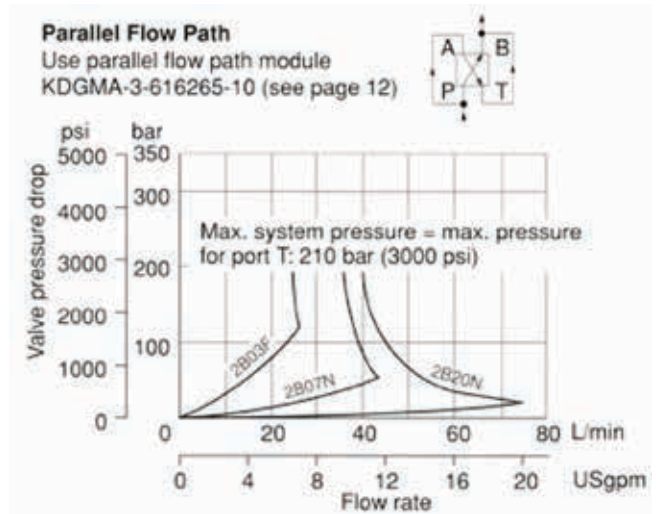
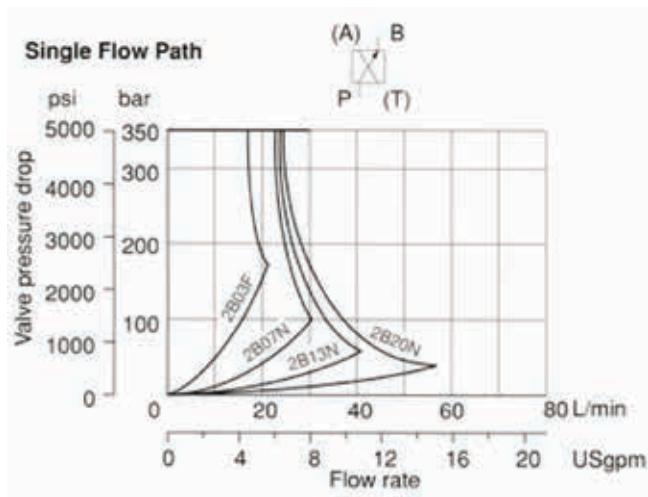
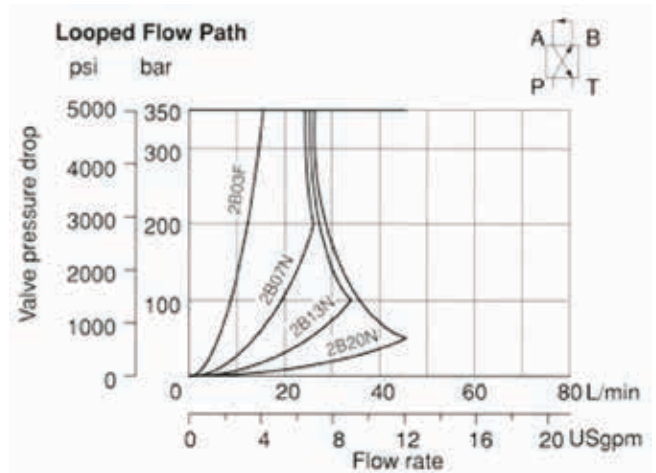

Double solenoid models:

K(B)FDG4V-3

Spool types as noted

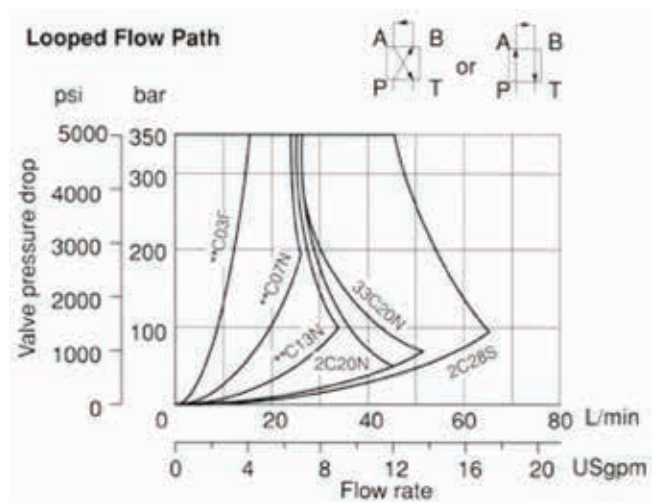
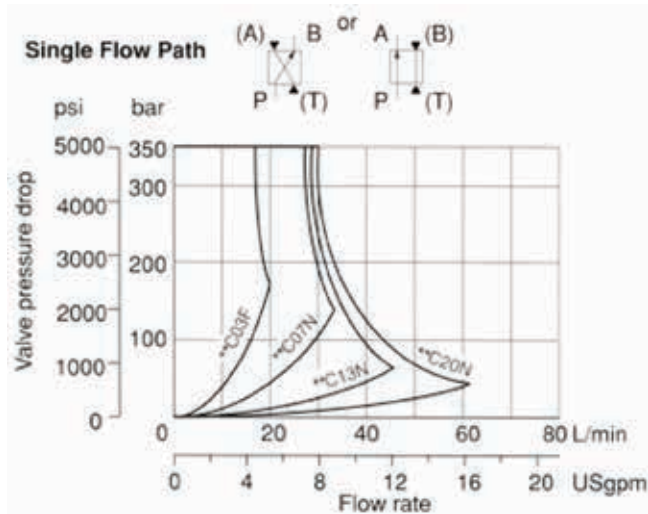

Performance curves

Flow gain curves

When using the single solenoid throttle valves version (K*FT) a parallel flowpath module can be used to approximately double the flow rate.

KBF valves are preset at the factory to compensate for the effect of spool overlap. Curves shown include deadband compensation provided for the KF valve by Eaton's Eaton Eurocard Amplifier EEA-PAM-533-*-*32 (user adjustable).

K(B)FD/TG4V-3

Spool types as noted

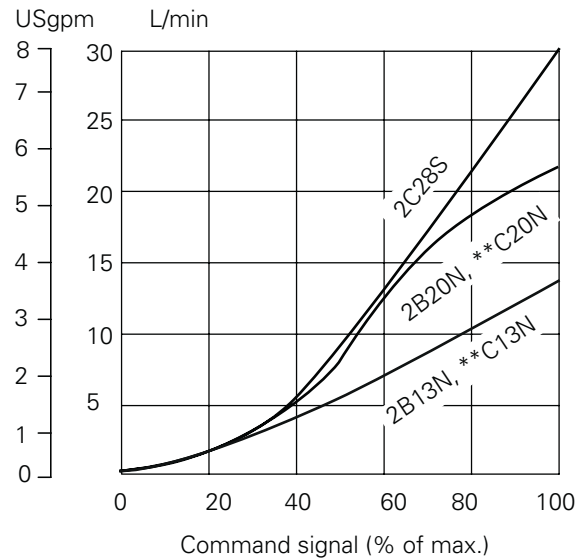
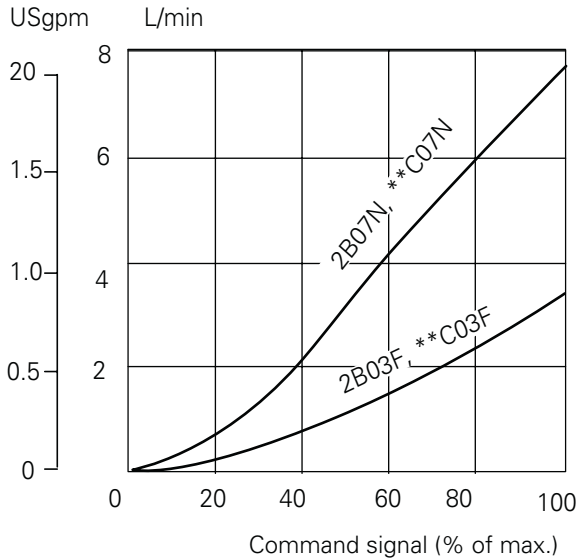

Single flowpath (e.g. P-A) pressure drop, $\Delta p = 5 \text{ bar (72 psi)}$. ■ ■ At other Δp values and within the power capacity envelopes, flow rates approximate to:

Frequency response (typical)

For an amplitude of $\pm 25\%$ max. flow about the 50% flow, at $\Delta p (P-B) = 5 \text{ bar (72 psi)}$

KBFD/TG4V-3

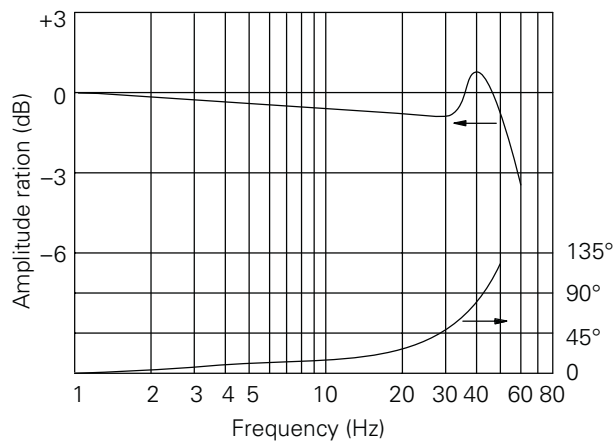

KFD/TG4V-3

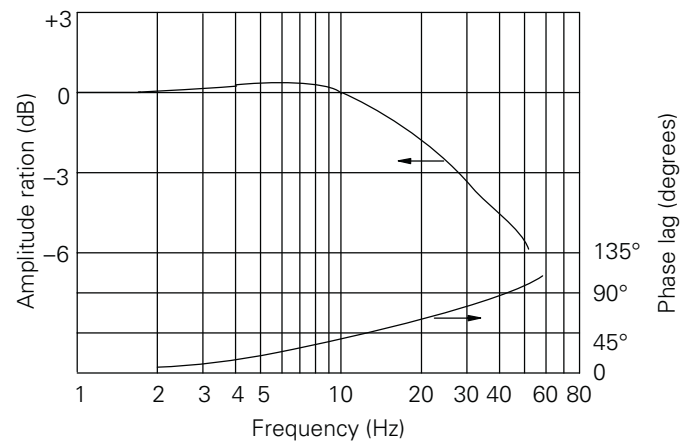

Installation dimensions

KFDTG4V-3 / KFTG4V-3

Spool types as noted

Solenoid plug (ISO 4400/DIN 43650); gray, marked A, for V models, or black, marked B, for non-V models; see **15** in "Model Code"

Solenoid plug (ISO 4400/DIN 43650); black, marked B, for V models, or gray, marked A, for non-V models; see **15** in "Model Code"

KFDG4V-3

mm (inch)

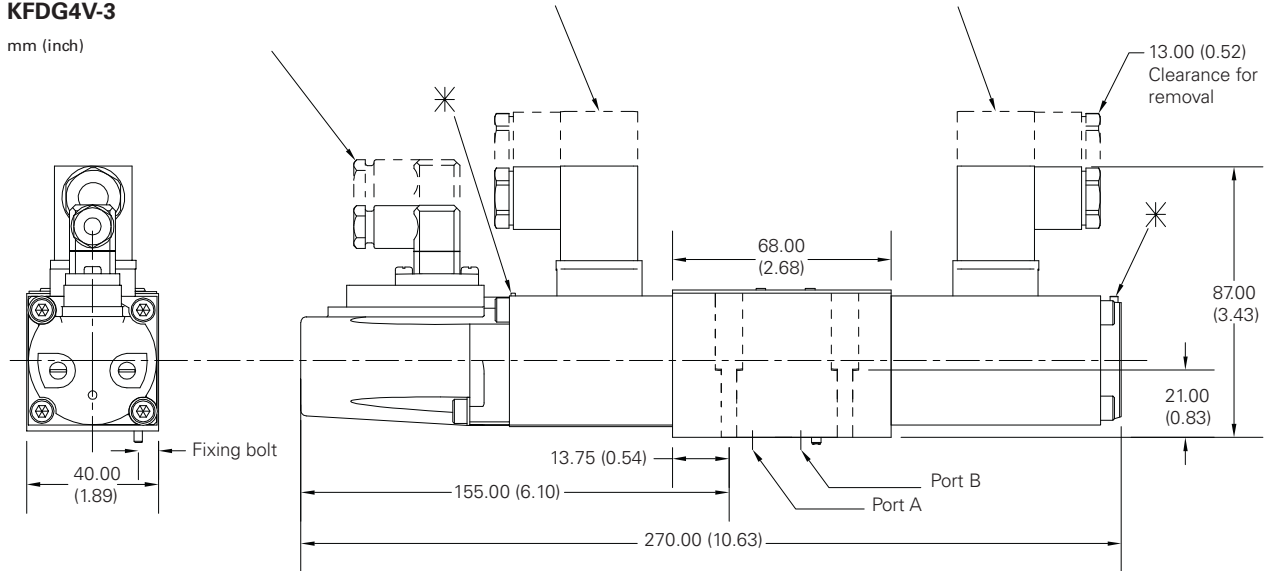

KFTG4V-3

mm (inch)

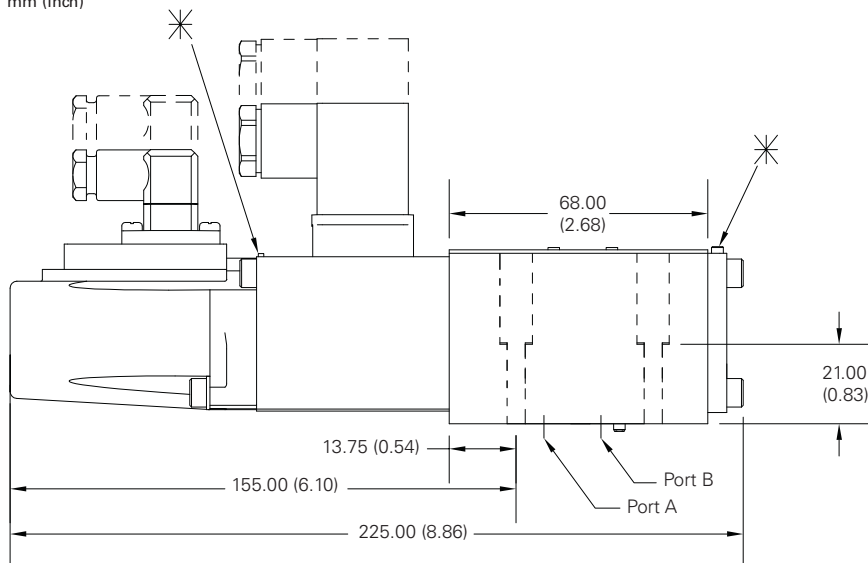

▲ Mounting surface seals supplied

Note: For optimum valve operation, bleed the air from the proportional solenoids at initial start-up. This may be done as follows:

- The valve may be pressurized by removing the bleed screws until no bubbles appear and then reinstalling bleed screws, or
- Remove both bleed screws, and use a standard oil can nozzle to pump fluid in one side until it flows, free of air bubbles, out the other side. Reinstall screws.

If there is no inherent back pressure in the tank port of the circuit do not allow the tank line to empty. This may be prevented by installing a check valve in the tank line. The cracking pressure of the check valve should be in the range of 22 - 45 psi (1.5 - 3 bar).

KBFDG4V-3

mm (inch)

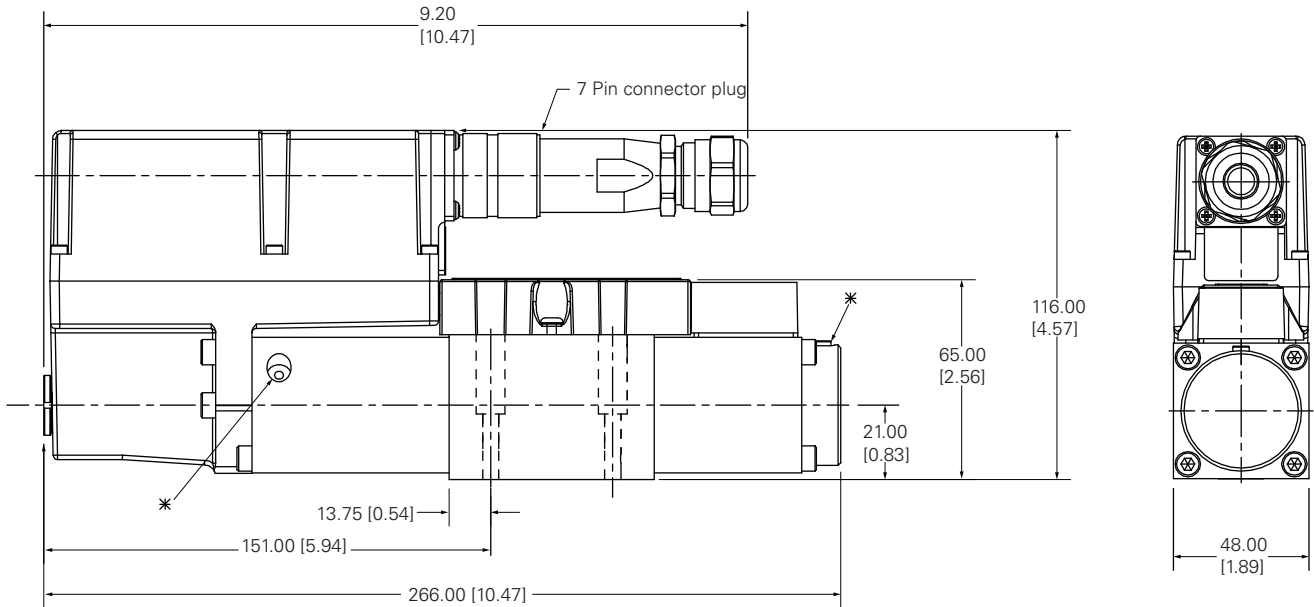

KBFTG4V-3

mm (inch)

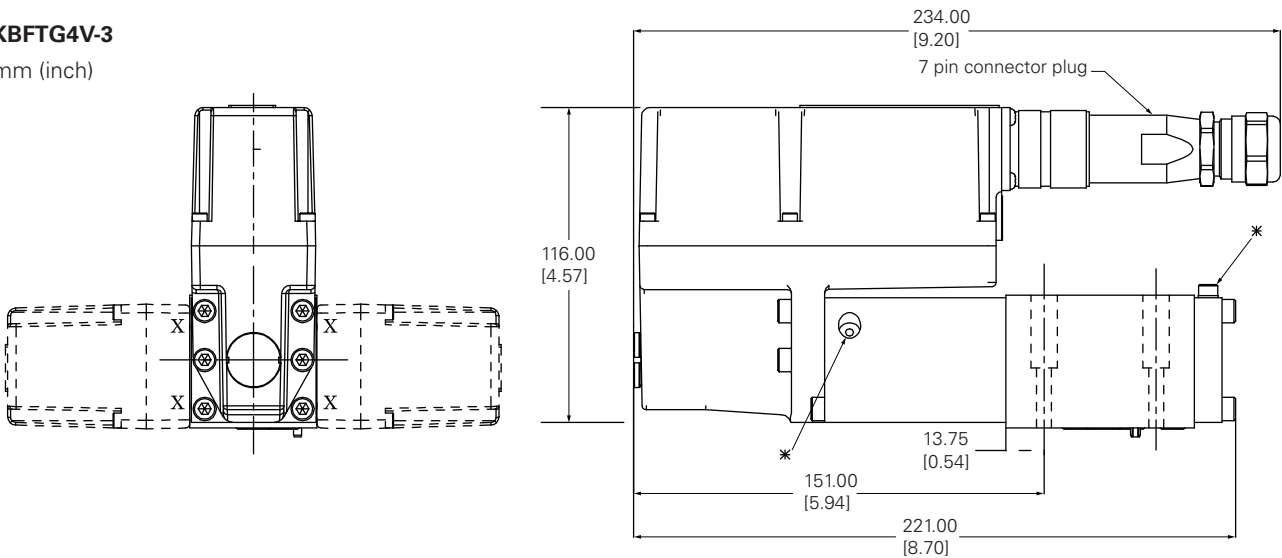

Amplifier and solenoid may be rotated 90° as shown by removing 4 screws shown X. Re-torque to 7-9 Nm (6-7 lbf ft)

* Bleed screw locations Air bleed, Socket Head Cap Screw. Torque to 2.5-3.0 Nm (2.0- 2.5 lbf ft)

WARNING

Valves with integral amplifiers are supplied with or without the metal 7-pin plug. The Eaton plug, part no. 934939, must be correctly fitted to ensure that the EMC rating and IP67 rating are achieved. The plug retaining nut must be tightened with a torque of 2.0- 2.5 Nm (1.5-2.0 lbf ft) to effect a proper seal.

Subplates and mounting surfaces

Mounting surface to ISO 4401 (Size 03)

This interface conforms to: ISO 4401-03-02-0-05

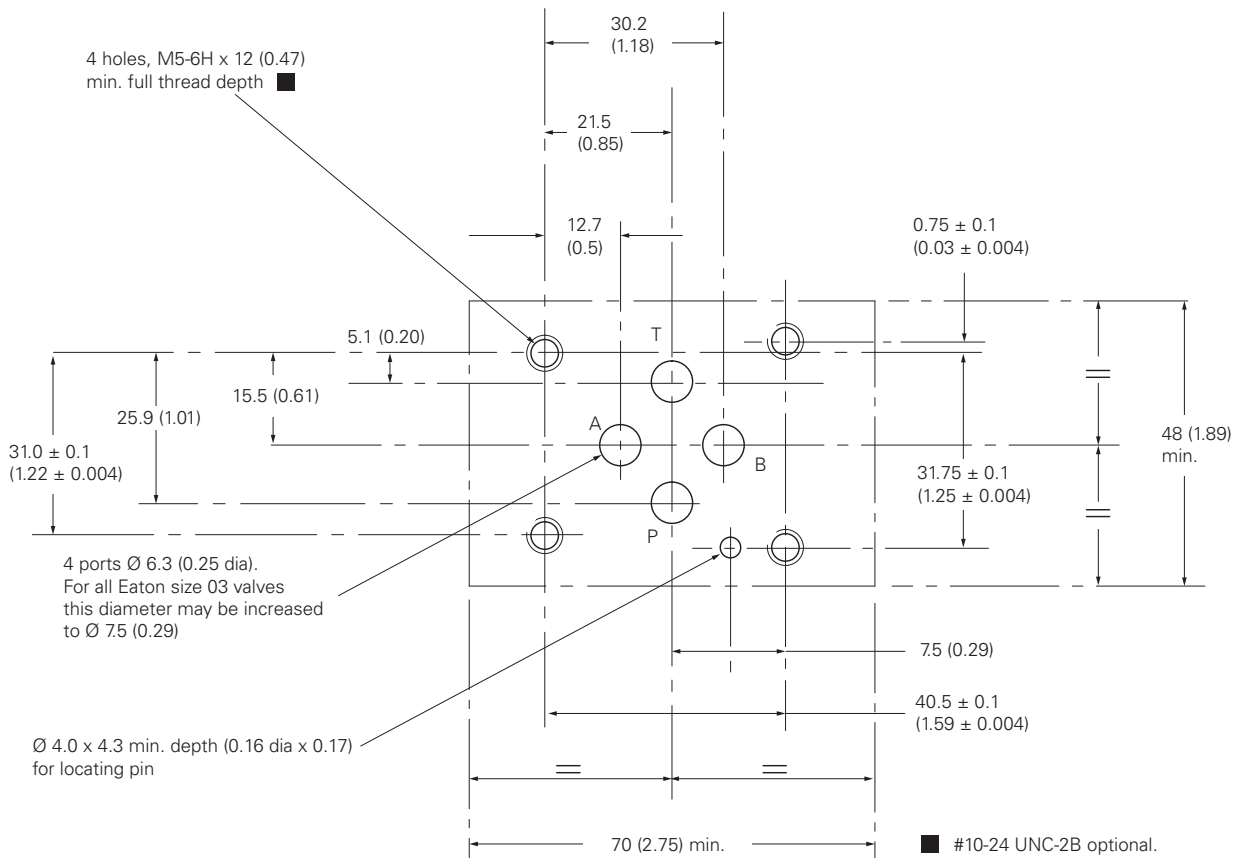

■ #10-24 UNC-2B optional

Interface with additional drain port

ANSI/B93.7M (and NFPA) size 03 CETOP R35H4.2-4-03, plus location pin hole.

Typically used for proportional and other valves requiring an additional drain port.

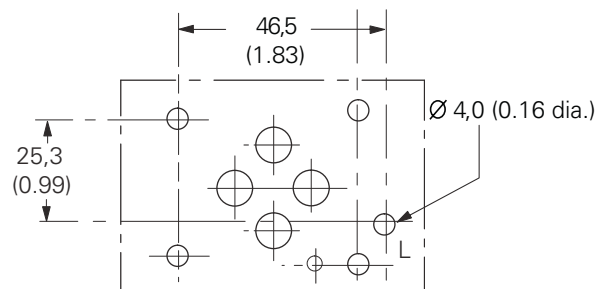

Block diagram Voltage input (M1) KBFDG 4V-3

KBFDG4V-3 wiring

Wiring Connections must be made via the 7-pin plug mounted on the amplifier. See page 15 of this leaflet and Eaton's Installation Wiring Practices for Eaton Electronic Products, leaflet 2468.

Recommended cable sizes are:

Power cables:

For 24V supply 0.75 mm² (18 AWG) up to 20m (65 ft)
1.00 mm² (16 AWG) up to 40m (130 ft)

Signal cables:

0.50 mm² (20 AWG)

Screen (shield):

A suitable cable would have seven cores, a separate screen for the signal wires and an overall screen.

Cable outside diameter 8.0– 10.5 mm (0.31–0.41 inches)

See connection diagram on page 15.

KFDG4V-3 wiring

Wiring details for these valves are contained in the appropriate Eurocard literature and Eaton's Installation Wiring Practices for Eaton Electronic Products leaflet 2468.

Command signals and outputs, M1

7-pin plug		Flow direction
Pin D	Pin E	
Positive	0V	
0V	Negative	P to A
	$U_d - U_e = \text{Positive}$	
Negative	0V	
0V	Positive	P to B
	$U_d - U_e = \text{Negative}$	

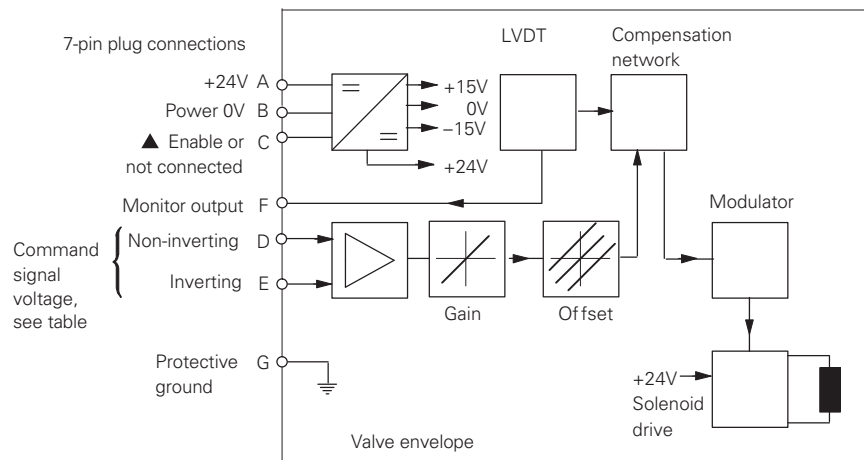

▲ Pin C is used for a valve enable signal with electrical connections PH7

WARNING

All power must be switched off before connecting or disconnecting any plugs.

Electrical information

Block diagram Current input (M2) KFSDG4V-3

KBSDG4V-3 wiring

Connections must be made via the 7-pin plug mounted on the amplifier. See page 15 of this leaflet and Eaton's Installation Wiring Practices for Eaton Electronic Products, leaflet 2468.

Recommended cable sizes are:

Power cables:

For 24V supply 0.75 mm² (18 AWG) up to 20m (65 ft) 1.00 mm² (16 AWG) up to 40m (130 ft)

Signal cables:

0.50 mm² (20 AWG)

Screen (shield):

A suitable cable would have seven cores, a separate screen for the signal wires and an overall screen.

Cable outside diameter 8.0– 10.5 mm (0.31–0.41 inches)

See connection diagram on page 16.

KFDG4V-3 wiring

Wiring details for these valves are contained in the appropriate Eurocard literature and Eaton's Installation Wiring Practices for Eaton Electronic Products leaflet 2468.

Command signals and outputs, M2

7-pin plug			
Pin D	Pin E	Pin B	Flow direction
More than 12 mA	Current return	Power ground	P to A
Less than 12 mA	Current return	Power ground	P to B

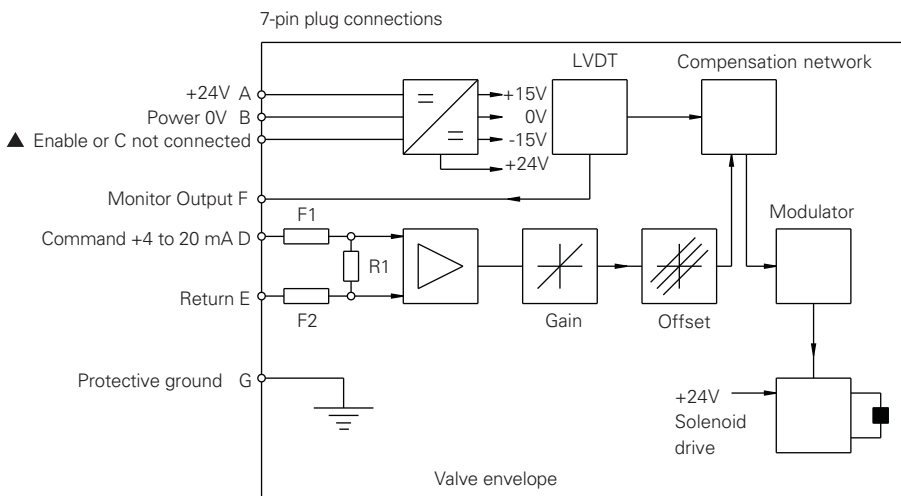

- ▲ Pin C is used for a valve enable signal with electrical connections PH7.
- R1 Shunt resistor 100R
- F1, F2 Resettable fuse

WARNING

All power must be switched off before connecting/ disconnecting any plugs.

Electrical information

Wiring connections Voltage input (M1)

■ Spool position monitor voltage (pin F) will be referenced to the KB valve local ground.

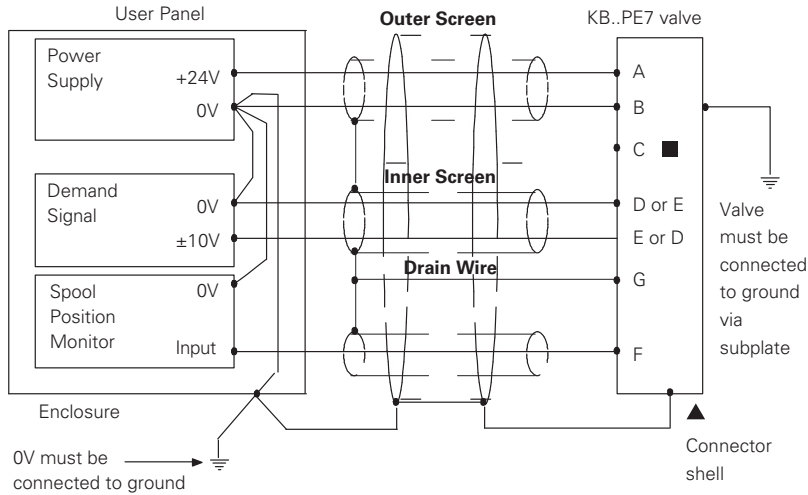

Wiring connections for M1 valves with enable feature

Note: ■ In applications where the valve must conform to European RFI/EMC regulations, the outer screen (shield) must be connected to the outer shell of the 7-pin connector, and the valve body must be fastened to the earth ground. Proper earth grounding practices must be observed in this case, as any differences in command source and valve ground potentials will result in a screen (shield) ground loop.

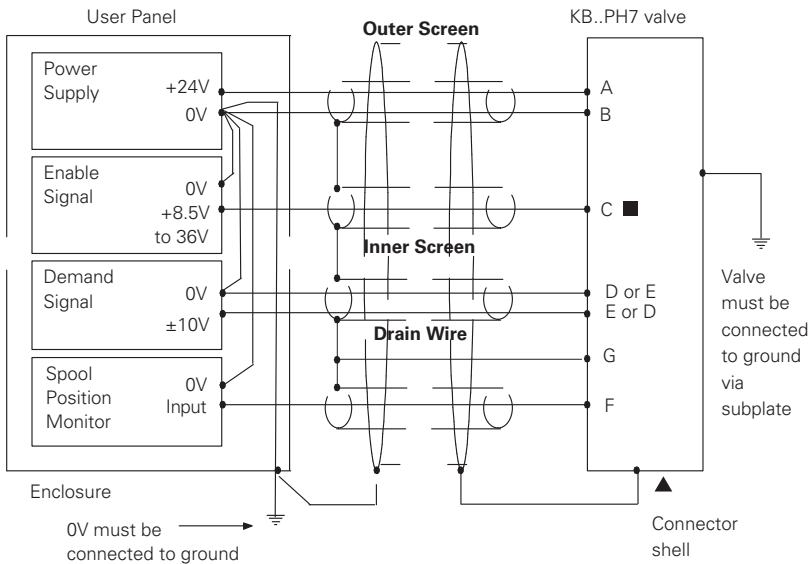

Wiring connections Current input (M2)

Spool position monitor voltage (pin F) will be referenced to the KB valve local ground.

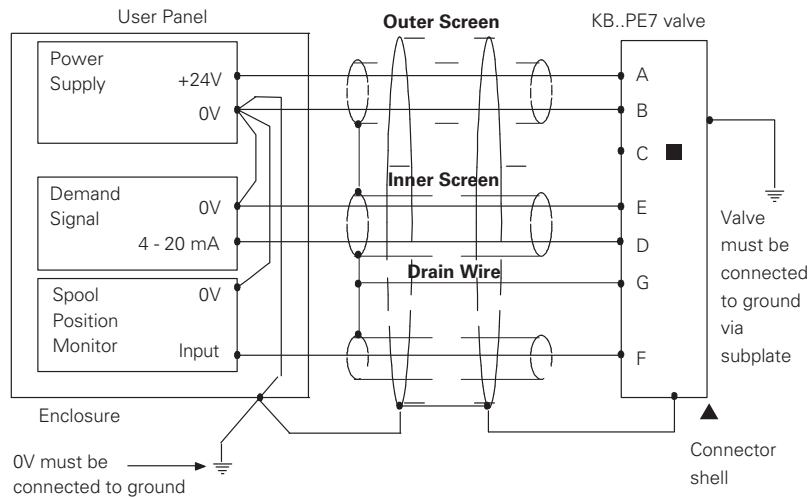

Wiring connections for M2 valves with enable feature

In applications where the valve must conform to European RFI/EMC regulations, the outer screen (shield) must be connected to the outer shell of the 7-pin connector, and the valve body must be fastened to the earth ground. Proper earth grounding practices must be observed in this case, as any differences in command source and valve ground potentials will result in a screen (shield) ground loop.

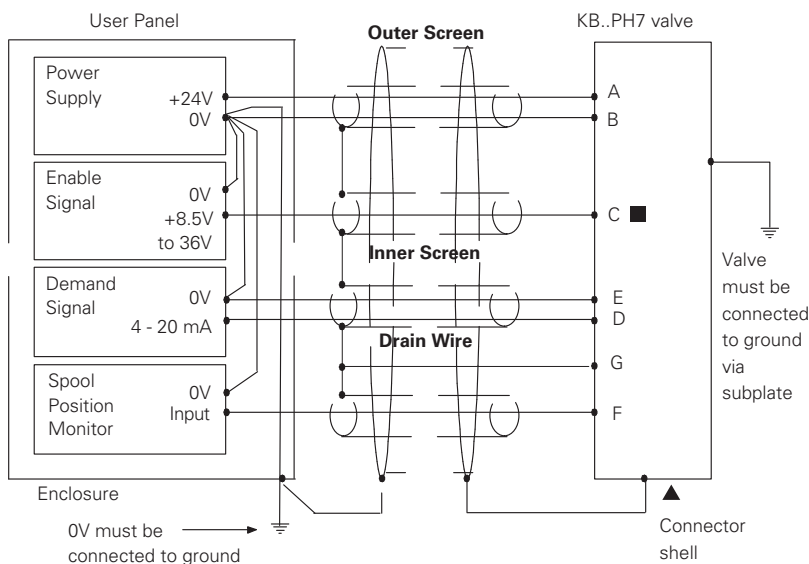

⚠ WARNING

Electromagnetic Compatibility (EMC)
It is necessary to ensure that the valve is wired up as above. For effective protection the user electrical cabinet, the valve subplate or manifold and the cable screens should be connected to efficient ground points.

The metal 7-pin connector part no. 934939 should be used for the integral amplifier. In all cases both valve and cable should be kept as far away as possible from any sources of electromagnetic radiation such as cables carrying heavy current, relays and certain kinds of portable radio transmitters, etc. Difficult environments could mean that extra screening may be necessary to avoid the interference.

It is important to connect the 0V lines as shown above. The multi-core cable should have at least two screens to separate the demand signal and monitor output from the power lines.

The enable line to pin C should be outside the screen which contains the demand signal cables.

Application data

Fluid cleanliness

Proper fluid condition is essential for long and satisfactory life of hydraulic components and systems. Hydraulic fluid must have the correct balance of cleanliness, materials and additives for protection against wear of components, elevated viscosity and inclusion of air.

Recommendations on contamination control methods and the selection of products to control fluid condition are included in Eaton's publication 9132 or 561, "Eaton Guide to Systemic Contamination Control". The book also includes information on the Eaton's concept of "ProActive Maintenance".

The following recommendations are based on ISO cleanliness levels at 2 µm, 5 µm and 15 µm:

For products in this catalog the recommended levels are:

0 to 70 bar (1000 psi)	18/16/13
70 + bar (1000 + psi)	17/15/12

Eaton products, as any components, will operate with apparent satisfaction in fluids with higher cleanliness codes than those described. Other manufacturers will often recommend levels above those specified.

Experience has shown, however, that life of any hydraulic components is shortened in fluids with higher cleanliness codes than those listed above. These codes have been proven to provide a long trouble-free service life for the products shown, regardless of the manufacturer.

Hydraulic fluids

Materials and seals used in these valves are compatible with antiwear hydraulic oils, and non-alkyl-based phosphate esters. The extreme operating viscosity range is 500 to 13 cSt (2270 to 70 SUS) but the recommended running range is 54 to 13 cSt (245 to 70 SUS).

Installation

The proportional valves in this catalog can be mounted in any attitude, but it may be necessary in certain demanding applications, to ensure that the solenoids are kept full of hydraulic fluid. Good installation practice dictates that the tank port and any drain port are piped so as to keep the valves full of fluid once the system start-up has been completed.

Service information

The products from this range are preset at the factory for optimum performance; disassembling critical items would destroy these settings. It is therefore recommended that should any mechanical or electronic repair be necessary they should be returned to the nearest Eaton repair center. The products will be refurbished as necessary and retested to specification before return.

Field repair is restricted to the replacement of the seals.

Note: The feedback/solenoid assembly installed in this valve should not be disassembled.

Eaton
Hydraulics Operations USA
14615 Lone Oak Road
Eden Prairie, MN 55344
USA
Tel: 952-937-9800
Fax: 952-294-7722
www.hydraulics.eaton.com

Eaton
Hydraulics Operations Europe
Route de la Longeraie 7
1110 Morges
Switzerland
Tel: +41 (0) 21 811 4600
Fax: +41 (0) 21 811 4601

Eaton
Hydraulics Operations Asia Pacific
11th Floor Hong Kong New World Tower
300 Huaihai Zhong Road
Shanghai 200021
China
Tel: 86-21-6387-9988
Fax: 86-21-6335-3912

Eaton
EMEA Headquarters
Route de la Longeraie 7
1110 Morges, Switzerland
Eaton.eu

© 2017 Eaton
All Rights Reserved
Publication No. V-VLPO-MC007-E2/3826
November 2017

Changes to the products, to the information contained in this document, and to prices are reserved; so are errors and omissions. Only order confirmations and technical documentation by Eaton is binding. Photos and pictures also do not warrant a specific layout or functionality. Their use in whatever form is subject to prior approval by Eaton. The same applies to Trademarks (especially Eaton, Moeller, and Cutler-Hammer). The Terms and Conditions of Eaton apply, as referenced on Eaton Internet pages and Eaton order confirmations.

Eaton is a registered trademark.

All trademarks are property of their respective owners.

